

EP1
Installation Instruction Brochure

**CHILD CHECK-MATE™ SAFETY
SYSTEM**



and check!

CHILD CHECK-MATE SYSTEMS INC.
U.S. Patent #5874891

Installation Instruction Brochure

“This brochure is a supplement to the Installation Training Video”

The Child Check-Mate/Theft-Mate Safety System (CCMS) is made up of Two main components.

The first is the **EP1 Alarm Unit**, which is mounted at the front of the bus near the driver and comes a six-pin harness and a dome light relay harness.

The second, is the **Rear Vehicle Transmitter (RVT-Reset Button)** that is mounted on the inside rear of the bus. Note: Some RVT installations will require a “Conduit Kit”.

Questions relating to the installation should be directed to Installation, Child Check-Mate Systems Inc. ccms@childcheckmate.com or directly at 613-835-9828.







Installing the EP1 Alarm Unit

Location and Mounting:

- Locate a convenient mounting area for the EP1 Alarm Unit within the main electrical panel at the front of the bus. Before securing the unit, check to ensure that its location is central enough so that the plug leading from the wires can reach it easily once all the wires have been connected.
- Secure the unit to the wall using the two-sided tape provided.
- Once mounted, screws may be applied to the holes located at each end of the Unit.

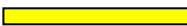
Connecting the 6 wire harness for the EP1 Alarm Unit:

- Before plugging into the EP2 Alarm Unit, connect wiring harness as follows;

1)	BATTERY	- RED WIRE	
2)	GROUND	- BLACK WIRE	
3)	IGNITION	- YELLOW WIRE	
4)	FRONT WARNING BUZZER	- BLUE WIRE	
5)	OVERHEAD FLASHING LIGHTS	- BROWN WIRE	
6)	VEHICLE HORN	- GREEN WIRE	

- Connect the RED wire to battery 12 volts. (Positive all the time)
- Connect the BLACK wire to a good ground connection.
- Connect the YELLOW wire to ignition - 12 volts.
- Find the front warning buzzer of the bus. On this buzzer there are two wires - one wire runs to the rear door switch, the second wire becomes positive when ignition is turned on. Join the BLUE wire of the Child Check-mate system to the wire running to the rear door switch.
- The brown wire is the activation wire, connect to the overhead lights and ensure it becomes live whenever the **overhead lights are activated**. Ensure that the brown wire **“is not”** connected to the master switch.
- Find the horn relay of the bus and connect the GREEN wire to the ground side of the horn relay. NOTE: You may need to run extra (18 gauge) wire if the relay or ground wire is located under the steering column. If there is no horn relay, a relay must be installed.
- DO NOT PLUG HARNESS INTO EP1 AT THIS TIME

Optional

Adding Dome Light Harness and Brake Signal Harness

Connections for the 2 pin Harness;

- 1) BRAKE - GREY 
 - Connect the Grey wire to the brake light wiring. This wire should have 12 volts on it when the brake pedal is depressed and brake lights are activated.
- 2) Find the wire leading from the dome light switch to the dome lights in the electrical box. This dome light wire must be cut.

Make the following Connections;

- BLUE Wire from EP1 Dome Light Harness, Connect to wire leading towards dome lights.
- RED Wire – Connect to wire leading from dome light switch
- RED Fused Wire – Connect to 12 volt battery positive

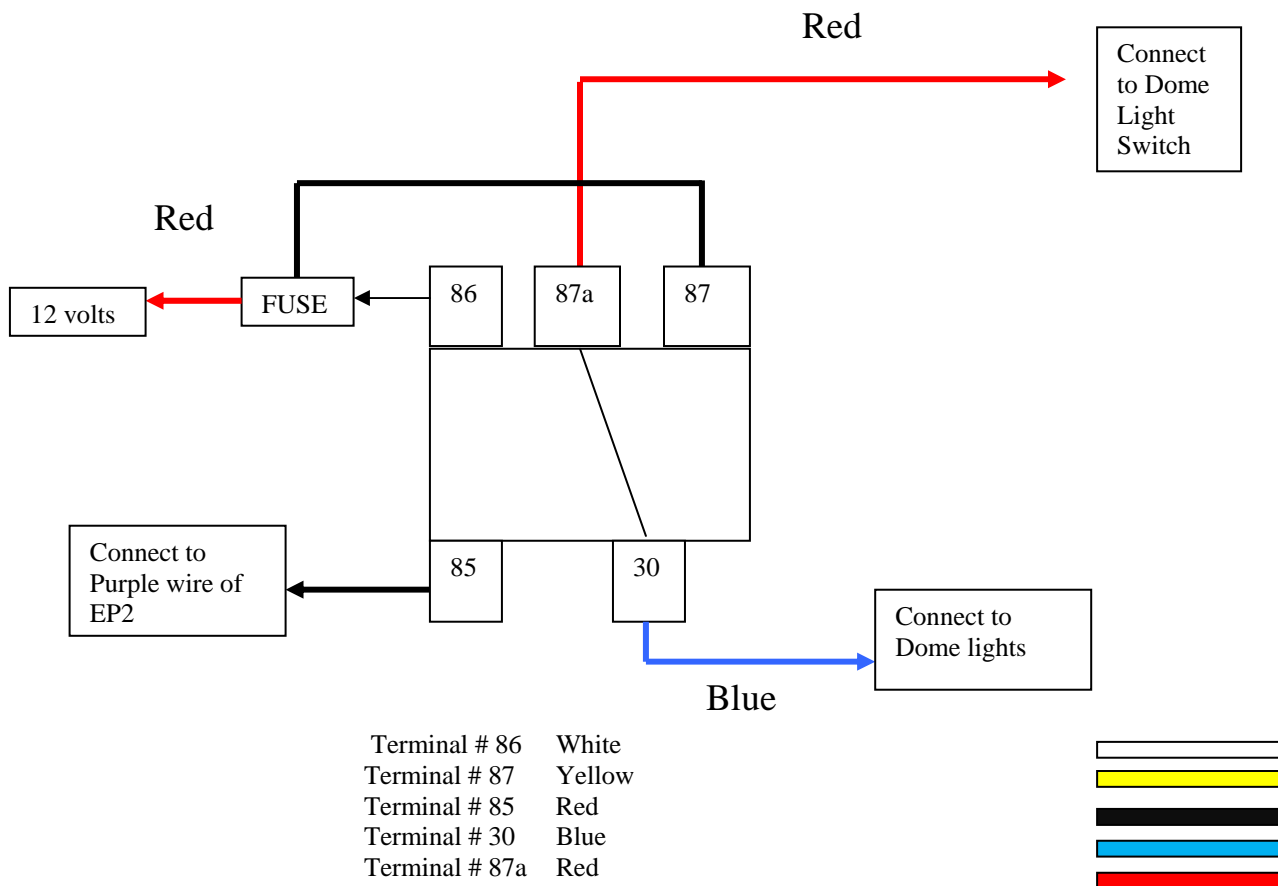

The Installation of the Dome Light wiring at the front of the bus is complete.

Installing the Rear Vehicle Transmitter (RVT-Reset Button)

Location and Mounting:

The RVT can be mounted two different ways depending upon whether the bus is “rear engine” or “conventional” rear door model.

Rear Engine Buses

On rear engine buses, the wires extend out of the “back” of the unit directly into the wall panel. The RVT is mounted above the window on the bus wall over the furthest rear seat on the driver’s side of the bus. The RVT is connected to the furthest rear window or side door buzzer. The following steps describe the proper mounting procedures for rear engine buses:

1. Drill a 23/64th-inch hole at desired location over the rear seat.
2. Insert plastic grommet, (supplied) into drilled hole.
3. Loosen panels required to run the two wires to the closest emergency buzzer. This could be either the rear emergency window buzzer or the side emergency door buzzer.
4. Feed the two wires out the “back” of the RVT and through the pre drilled hole and secure it to the panel with the top screw (supplied). **IMPORTANT:** The lock washer provided **MUST** be installed between the bus body and the Rear Vehicle Transmitter to ensure a good ground.
5. Place the small plug (supplied) over the two remaining holes at the bottom of the Rear Vehicle Transmitter secure to panel.
6. Refer to “connecting the RVT wires” on following page.

Conventional Buses

For installation on conventional bus models, the RVT can be mounted directly on a panel, on the left side above the last seat. The wires can extend out of the back of the RVT and connected directly into the existing bus harness behind this panel. The RVT can then be directly secure to this panel. **REMEMBER** this panel must be grounded for the system to operate properly

Alternatively, the wires can extend out of the “bottom” of the unit using an optional “Conduit Kit” Model RVT-2Wc available from Child Check-Mate. The RVT is mounted at the top right of the rear emergency doorframe, and is connected to the rear door buzzer thorough the conduit. The following describes the proper mounting procedures when installing on a conventional bus:

1. Prepare the Buzzer housing as shown below if using a conduit mount, or; drill a hole and fish wires following the installation procedures outlined above for Rear Engine Models.
2. With the two wires running out the “bottom” of the RVT, mount the unit to the doorframe with the three self-tapping screws (supplied). **REMEMBER: The lock washer supplied must be installed between the bus panel and the Rear Vehicle Transmitter to ensure a good ground.**
3. Measure the desired length of the conduit to be cut. Allow for any bends necessary then add ½ of an inch for the conduit to be inserted into the buzzer housing and the RVT.
4. Once the conduit has been cut, feed the two wires through the conduit and push the conduit just inside the Rear Vehicle Transmitter about 1/8th of an inch. Do not force the conduit too far into the RVT
5. Bend the conduit along the path chosen and secure the conduit to the bus with the “P” clips and screws (supplied). Because of the thickness of the doorframe, it will be necessary to pre drill the screw holes.
6. **Refer to “connecting the RVT wires” on following page.**

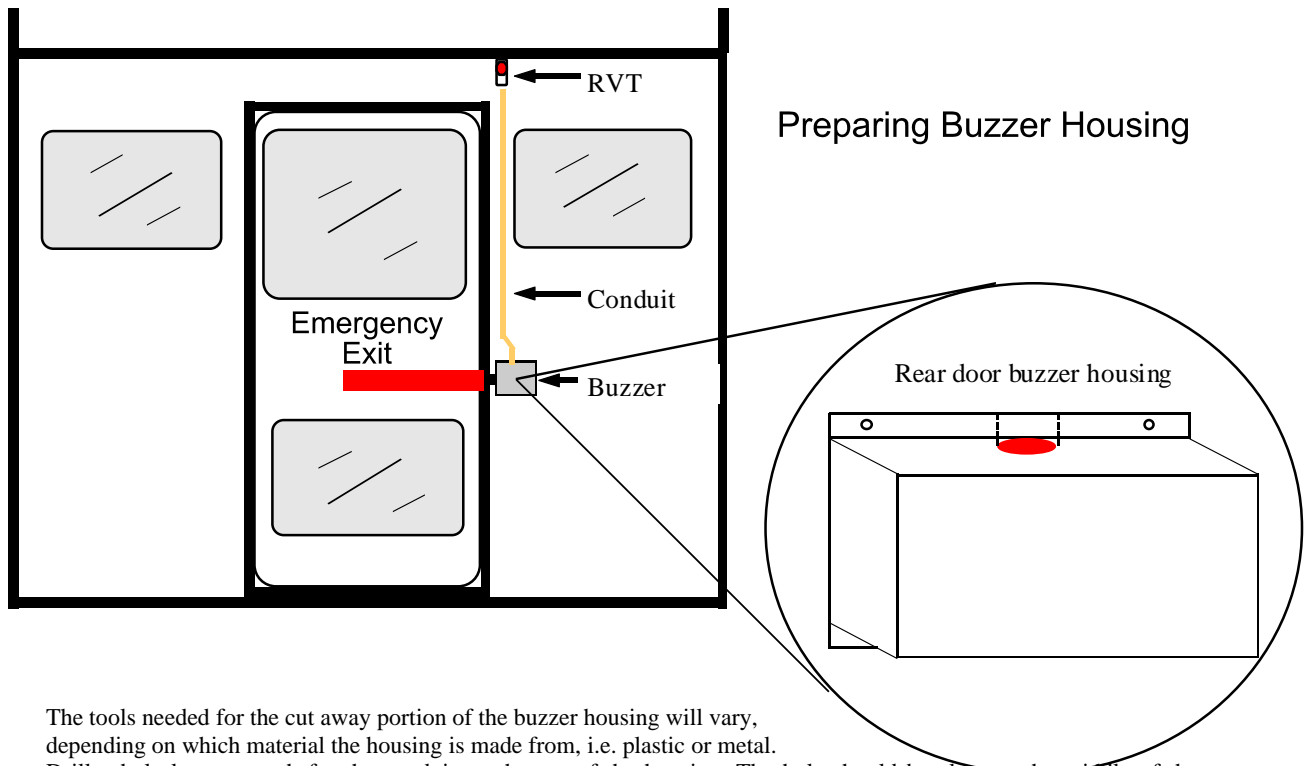

The tools needed for the cut away portion of the buzzer housing will vary, depending on which material the housing is made from, i.e. plastic or metal. Drill a hole large enough for the conduit on the top of the housing. The hole should be close to the middle of the housing, tight against the mounting flange of the housing. *See area marked in red on housing diagram.* Cut away the mounting flange so it will meet up with both sides of the hole drilled as shown by a dotted line in the housing diagram. This cut out will allow removal of the buzzer housing in the future. While not disturbing the conduit.

Connecting the RVT wires:

- 1) GROUND SIDE OF BUZZER - BLUE WIRE
- 2) 12 VOLT IGNITION OF BUZZER - RED WIRE

- The Rear Vehicle Transmitter is to be wired to the closest emergency buzzer / switch assembly. Typically the rear emergency door or window.
- View the following diagrams to determine which switch is being used.
- Connect the BLUE wire to the wire running to the front buzzer.
- Connect the RED wire to the 12 volt side of the buzzer.

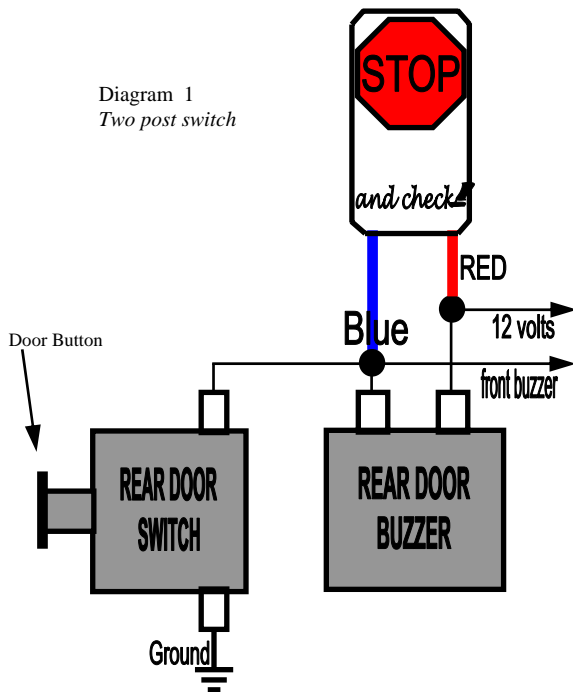

Thin black wire = existing vehicle wire

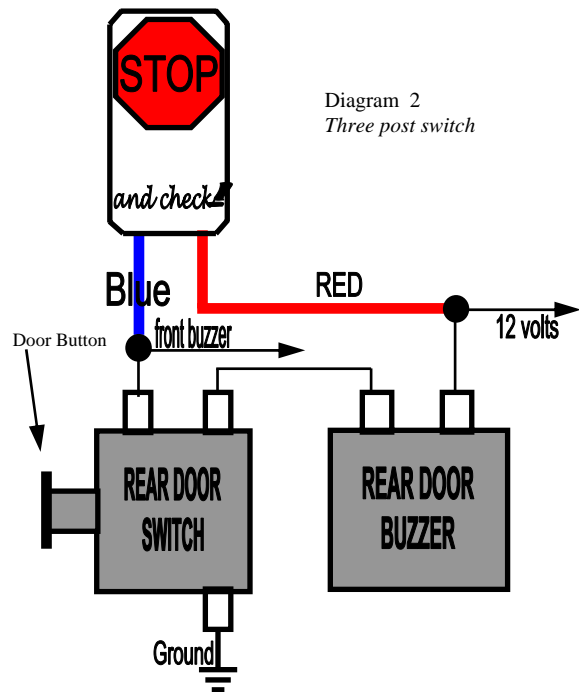

Thin black wire = existing vehicle wire

OPERATION CHECK LIST

CHILD CHECK COMPONENT;

1. Start the bus; you should hear an audible sound for the EP1 indicating that the system is functioning.
2. With the front door closed, turn the master switch on. Open the front door, the overhead lights should be flashing at this point. There should be an audible sound from EP1 the moment the Red Lights are activated. **Note: In California, to satisfy State regulations, the Brown can be connected to the marker lights. Using this feature the driver can escort children.** Close the front door, the overhead lights will stop flashing.
3. Turn the ignition off. The system alarm (a high pitched beeping) should begin to sound and the dome lights come on. After approximately 8 seconds the bus horn should start to pulsate off and on.
4. ***NOTE* The EP1 is designed in such a manner that the ignition key must be turned off for at least 1 second and then back on the ignition or accessory. The will allow for deactivation.**
5. Turn the ignition back “on” or to the “accessory” position; the alarm should be silenced in either position, the dome lights will remain on. Return to the rear of the bus and depress the reset button and hold for at least three seconds. You will hear a deactivation signal (a rapid chirping sound); the dome lights will remain on for 45 seconds. The system has now been deactivated and the key can be removed from the ignition.

