

Theft-Mate Installation Instruction Brochure

CHILD CHECK-MATE™ SAFETY SYSTEM



and check!

CHILD CHECK-MATE SYSTEMS INC.
U.S. Patent #5874891

Child Check-Mate/Theft-Mate Installation Instruction Brochure

“This brochure is a supplement to the Installation Training Video”

The Child Check-Mate/Theft-Mate Safety System (CCMS) is made up of four main components.

1. **EP2 Alarm Unit**, which is mounted in the electrical panel at the front of the bus near the driver.
2. **EP2 Power and Dome Light relay Harness** required to hook up Dome lights
3. **Rear Vehicle Transmitter (RVT-Reset Button)** that is mounted on the inside rear of the bus. Note: Some RVT installations will require a “Conduit Kit”.
4. **Theft-Mate Motion Sensor**, which is mounted at the interior front of the bus, just above the windshield directed to the middle of the bus.

Questions relating to the installation should be directed to Allan Lowe, VP Engineering, Child Check-Mate Systems Inc. cems@childcheckmate.com or directly at 613-835-9828.







Installing the EP2 Alarm Unit

Location and Mounting:



- Locate a convenient mounting area for the EP2 Alarm Unit within the main electrical panel at the front of the bus. Before securing the unit, check to ensure that its location is central enough so that the plugs leading from the EP2 Power and Dome Light Relay harness can reach it easily once all the wires have been connected.
- Secure the unit to the wall using the two-sided tape provided.
- Once mounted, screws may be applied to the holes located at each end of the Unit.

Connecting the EP2 Power and Dome Light Relay for the EP2 Alarm Unit:

- Before plugging into the EP2 Alarm Unit, connect wiring harness as follows;

1)	BATTERY	- RED WIRE (FUSED)	
2)	GROUND	- BLACK WIRE	
3)	IGNITION	- YELLOW WIRE	
4)	FRONT WARNING BUZZER	- SMALL BLUE WIRE	
5)	OVERHEAD FLASHING LIGHTS	- BROWN WIRE	
6)	VEHICLE HORN	- GREEN WIRE	
7)	BRAKE LIGHT SWITCH	- GREY WIRE	

SPARE WIRES in 5 pin harness (Not used at this time)

1)	GPS OUTPUT	- WHITE/BLACK WIRE	
2)	GPS OUTPUT	- WHITE/BROWN WIRE	
3)	SPARE	- ORANGE WIRE	

- Connect the RED Fused wire to battery 12 volts. (Positive all the time)
- Connect the BLACK wire to a good ground connection.
- Connect the YELLOW wire to small ignition terminal of the solenoid that is for the electrical power in the side driver’s panel - 12 volts.
- Find the front warning buzzer of the bus. On this buzzer there are two wires - one wire runs to the rear door switch, the second wire becomes positive when ignition is turned on. Join the BLUE wire of the Child Check-mate system to the wire running to the rear door switch.
- The brown wire is connected to the overhead lights and becomes live whenever the **overhead lights are activated**. Ensure that the brown wire “**is not**” connected to the master switch.
- Find the horn relay of the bus and connect the GREEN wire to the ground side of the horn relay. NOTE: You may need to run extra (18 gauge) wire if the relay or ground wire is located under the steering column. If there is no horn relay, a relay must be installed.
- Connect the GREY WIRE to the BRAKE LIGHT SWITCH. Connect this wire to the terminal of the switch that becomes 12 volts when the brake pedal is depressed.

Dome Light Wiring

Find the wire leading from the dome light switch to the dome lights in the electrical box. This dome light wire must be cut.

Make the following Connections;

- RED Wire – Connect to wire leading from dome light switch
- LARGE BLUE Wire - Connect to wire leading towards dome lights.

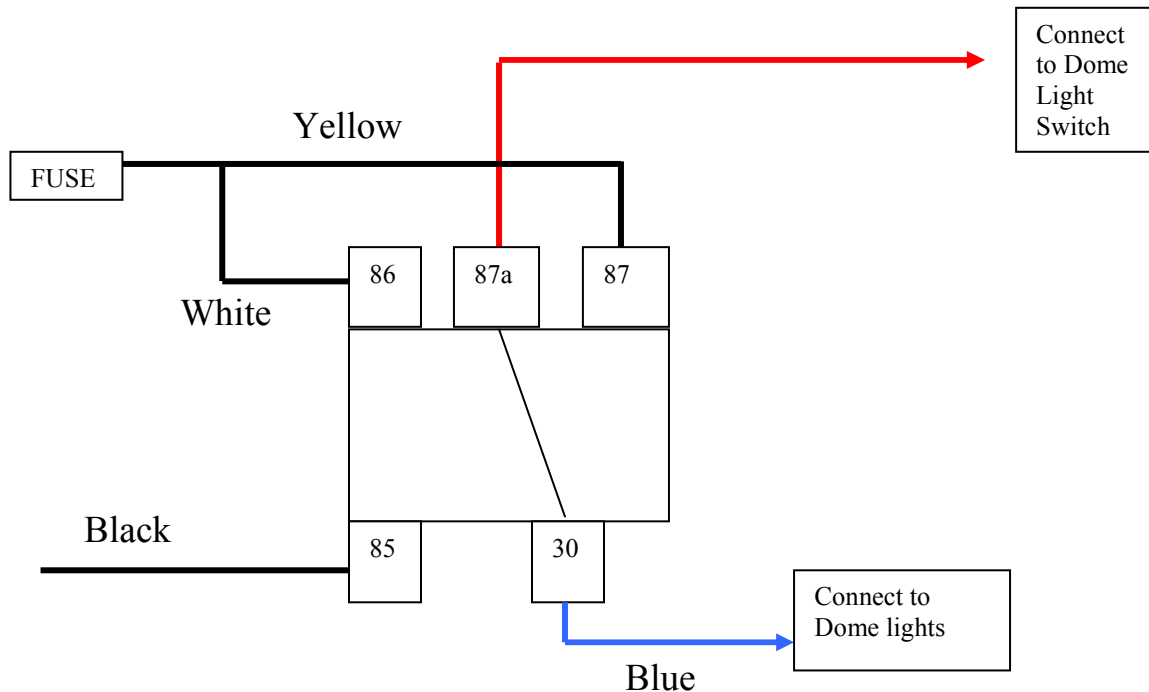

Installing Theft-Mate Motion Sensor

- This sensor will come with a 30cm length of wire attached to it and a separate 4 meter harness.
- The sensor is mounted directly above the windshield in the middle. Drill a $\frac{3}{4}$ hole and feed the harness through the panel where the sensor will be mounted.
- Run the Motion Sensor harness behind the panel to the driver's electrical box to the EP2 Module.
- Connect the motion sensor and mount to panel, it should be pointed to the rear of the bus. Extra caution must be taken as to have the Sensor in the proper position for the maximum benefit.

At this point, all harnesses can now be plugged in sequentially as follows:

1. The Sensor harness first;
2. The 5-pin harness second, and finally;
3. The 6-pin harness.

The Installation of the EP2 and Motion sensor at the front of the bus is complete.

Installing the Rear Vehicle Transmitter (RVT-Reset Button)

Extend the wires out of the “back” of the unit. The RVT is mounted above the window on the bus wall over the furthest rear seat on the driver’s side of the bus. The following steps describe the proper mounting procedures:

1. Drill a 23/64th-inch hole at desired location over the rear seat.
2. Insert plastic grommet, (supplied) into drilled hole.
3. Loosen panels required to run the two wires to the closest emergency buzzer. This could be either the rear emergency window buzzer or the side emergency door buzzer.
4. Feed the two wires out the “back” of the RVT and through the pre drilled hole and secure it to the panel with the top screw (supplied). **IMPORTANT:** The lock washer provided **MUST** be installed between the bus body and the Rear Vehicle Transmitter to ensure a good ground.
5. Place the small plug (supplied) over the two remaining holes at the bottom of the Rear Vehicle Transmitter secure to panel.
6. Refer to “connecting the RVT wires”

Connecting the RVT wires:

- | | | |
|----|----------------------------|-------------|
| 1) | GROUND SIDE OF BUZZER | - BLUE WIRE |
| 2) | 12 VOLT IGNITION OF BUZZER | - RED WIRE |



- Connect the BLUE wire to the wire running to the front buzzer.
- Connect the RED wire to the 12 volt side of the buzzer wiring.

CONDUIT KIT INSTALLATION METHOD

(Requires Optional Surface Mount Conduit Kit)

Alternatively, the wires can extend out of the “bottom” of the unit using an optional “Conduit Kit” Model RVT-2W available from Child Check-Mate. The RVT is mounted at the top right of the rear emergency doorframe, and is connected to the rear door buzzer through the conduit. The following describes the proper mounting procedures when installing on a conventional bus:

1. Prepare the Buzzer housing as shown below if using a conduit mount, or; drill a hole and fish wires following the installation procedures outlined above for Rear Engine Models.
2. With the two wires running out the “bottom” of the RVT, mount the unit to the doorframe with the three self-tapping screws (supplied). **REMEMBER: The lock washer supplied must be installed between the bus panel and the Rear Vehicle Transmitter to ensure a good ground.**
3. Measure the desired length of the conduit to be cut. Allow for any bends necessary then add ½ of an inch for the conduit to be inserted into the buzzer housing and the RVT.
4. Once the conduit has been cut, feed the two wires through the conduit and push the conduit just inside the Rear Vehicle Transmitter about 1/8th of an inch. Do not force the conduit too far into the RVT
5. Bend the conduit along the path chosen and secure the conduit to the bus with the “P” clips and screws (supplied). Because of the thickness of the doorframe, it will be necessary to pre drill the screw holes.

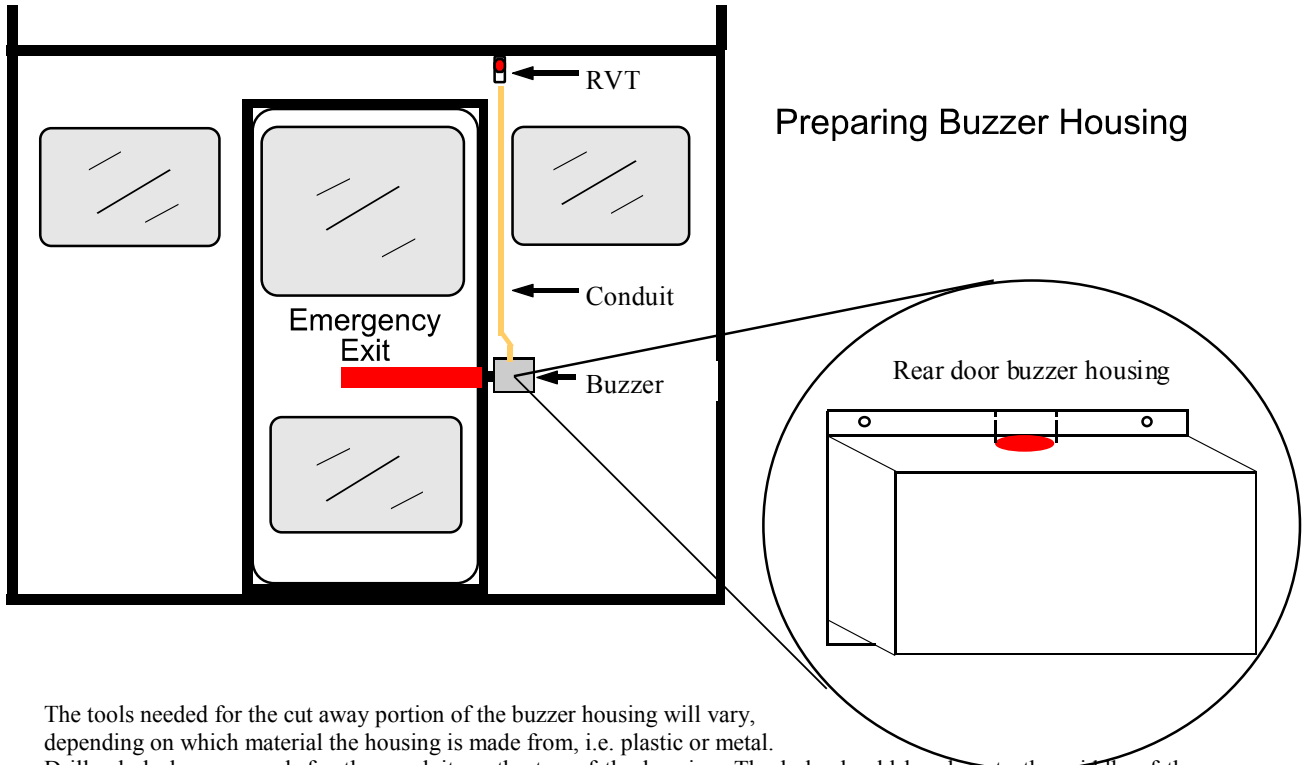

The tools needed for the cut away portion of the buzzer housing will vary, depending on which material the housing is made from, i.e. plastic or metal. Drill a hole large enough for the conduit on the top of the housing. The hole should be close to the middle of the housing, tight against the mounting flange of the housing. See area marked in red on housing diagram. Cut away the mounting flange so it will meet up with both sides of the hole drilled as shown by a dotted line in the housing diagram. This cut out will allow removal of the buzzer housing in the future. While not disturbing the conduit.

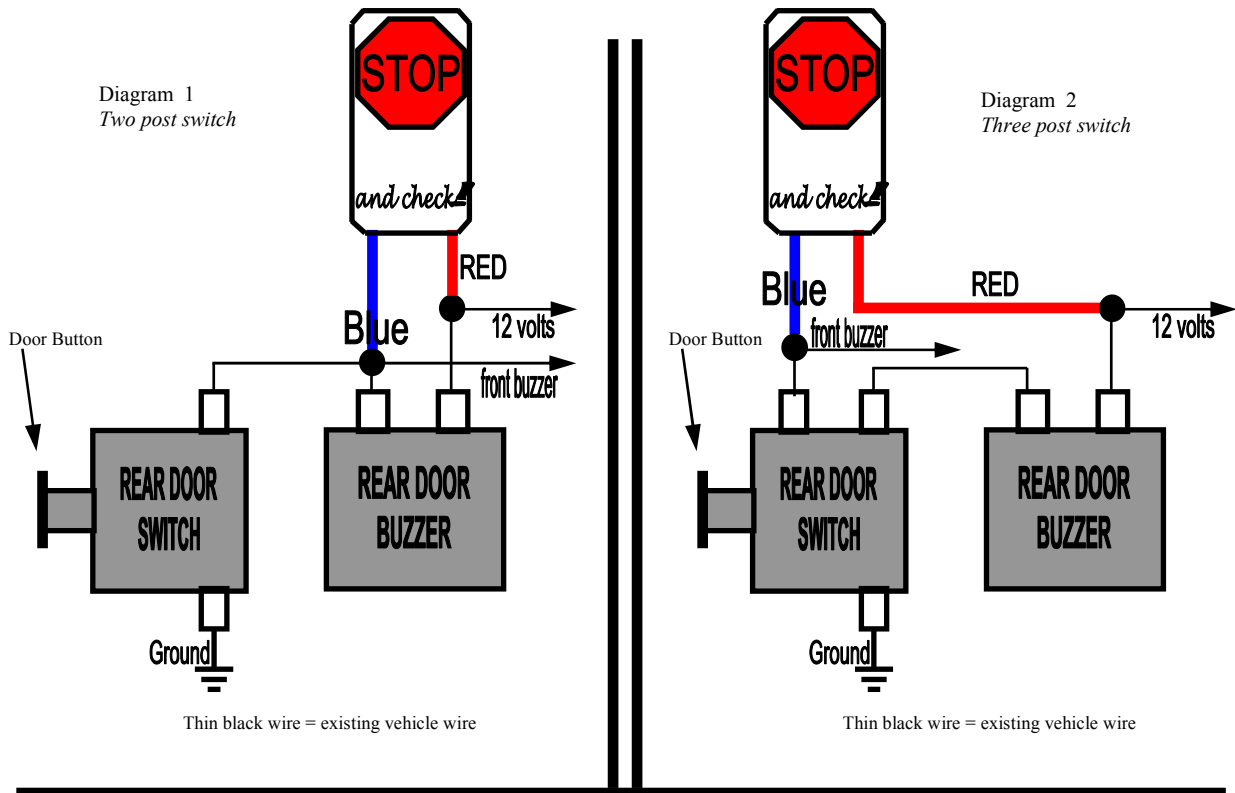

OPERATION CHECK LIST

CHILD CHECK COMPONENT;

1. Start the bus; you should hear an audible sound for the EP2 indicating that the system is functioning.
2. With the front door closed, turn the master switch on. Open the front door, the overhead lights should be flashing at this point. There should be an audible sound from EP2 the moment the Red Lights are activated.
Note: In California, to satisfy State regulations, the Brown can be connected to the marker lights. Using this feature the driver can escort children. Close the front door, the overhead lights will stop flashing. Turn the ignition off. The system alarm (a high pitched beeping) should begin to sound and the dome lights come on. After approximately 8 seconds the bus horn should start to pulsate off and on.
3. **NOTE**** the EP2 is designed in such a manner that the ignition key must be turned off for at least 1 second and then back to the ignition or accessory. This will allow for deactivation.
4. Turn the ignition back “on” or to the “accessory” position; the alarm should be silenced in either position, the dome lights will remain on. Proceed to the rear of the bus and depress the reset button and hold for at least three seconds. You will hear a deactivation signal (a rapid chirping sound); the dome lights will remain on for 60 seconds. The system has now been deactivated and the key can be removed from the ignition.
5. Check Operation of the brake wiring by depressing the brake pedal. The EP@ should sound an audible sound.

Theft-Mate Component

1. Let bus sit for **1 minute**. (Default Setting)
2. Walk onto bus, Dome lights should come on and initial passive alarm will sound after 15 seconds
3. The dome lights will pulsate off and on and the EP2 will sound a loud shrieking sound.
4. Turn the ignition key to the on position, this will silence the alarm.
5. The EP2 system is equipped with a RF receiver to disable the alarm for a predetermined time by the mechanic for maintenance. Perform the above steps and deactivate with the Key Fob. (Optional)

